

## W830

### ÊMBOLO ROSCADO EM AÇO COM FENDA PARA CHAVE DE PARAFUSOS

**Materiais:**

**W830:**  
Corpo do êmbolo em aço com classe de resistência 5.8.

**W830CIN:**  
Corpo do êmbolo em aço inoxidável (Aisi 303).

**Superfície:**

Lisa.

**Cor:**

**W830:**  
Preto do óxido.

**W830CIN:**  
Natural.

**Esfera:**

Esfera em aço inoxidável temperado (de rolamentos) (Aisi 420).

**Mola:**

**W830:**  
Mola em aço harmônico.

**W830CIN:**  
Mola em aço inoxidável (Aisi 301).

**Tipologia e força da mola:**

Normal.

**Pedidos especiais:**

- Nenhum.

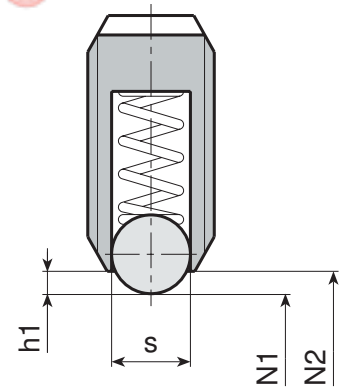
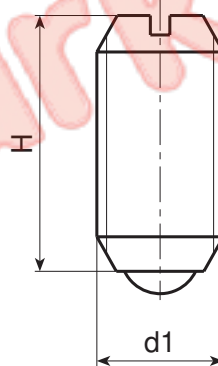

**Versão W830: em aço preto do óxido**

art.	s	H	h1	N1 (N)	N2 (N)	d1.6H	g
W830.VBM03	1.5	7	0.5	1.5	3	M3	0.2
W830.VBM04	2.5	9	0.8	4	10	M4	0.4
W830.VBM05	3	12	0.9	6	11	M5	0.9
W830.VBM06	3.5	14	1	9	13	M6	1.5
W830.VBM08	5	16	1.5	15	30	M8	3.5
W830.VBM10	6	19	2	20	35	M10	7
W830.VBM12	8	22	2.5	30	55	M12	10
W830.VBM16	10	24	3.5	65	125	M16	24
W830.VBM20	12	30	4.5	80	160	M20	44

**Versão W830 CIN - em aço inoxidável (Aisi 303)**

INOX

art.	s	H	h1	N1 (N)	N2 (N)	d1.6H	g
W830.INM03CIN	1.5	7	0.5	1.5	3	M3	0.2
W830.INM04CIN	2.5	9	0.8	4	10	M4	0.4
W830.INM05CIN	3	12	0.9	6	11	M5	0.9
W830.INM06CIN	3.5	14	1	9	13	M6	1.5
W830.INM08CIN	5	16	1.5	15	30	M8	3.5
W830.INM10CIN	6	19	2	20	35	M10	7
W830.INM12CIN	8	22	2.5	30	55	M12	10
W830.INM16CIN	10	24	3.5	65	125	M16	24
W830.INM20CIN	12	30	4.5	80	160	M20	44